

## Certification Report

### Security Chip MH1701 with IC Dedicated Software, V05

Sponsor and developer: **Beijing Megahunt Technologies Inc.**  
4th Floor, YinFeng Building, No.20, Suzhou Road  
Haidian district, Beijing  
China

Evaluation facility: **SGS Brightsight B.V.**  
Brassersplein 2  
2612 CT Delft  
The Netherlands

Report number: **NSCIB-CC-2400070-01-CR**

Report version: **1**

Project number: **NSCIB-2400070-01**

Author(s): **Haico Haak**

Date: **21 November 2025**

Number of pages: **13**

Number of appendices: **0**

*Reproduction of this report is authorised only if the report is reproduced in its entirety.*

# CONTENTS

<b>Foreword</b>	<b>3</b>
<b>Recognition of the Certificate</b>	<b>4</b>
International recognition	4
European recognition	4
<b>1 Executive Summary</b>	<b>5</b>
<b>2 Certification Results</b>	<b>6</b>
2.1 Identification of Target of Evaluation	6
2.2 Security Policy	6
2.3 Assumptions and Clarification of Scope	6
2.3.1 Assumptions	6
2.3.2 Clarification of scope	6
2.4 Architectural Information	7
2.5 Documentation	8
2.6 IT Product Testing	8
2.6.1 Testing approach and depth	8
2.6.2 Independent penetration testing	9
2.6.3 Test configuration	9
2.6.4 Test results	9
2.7 Reused Evaluation Results	9
2.8 Evaluated Configuration	9
2.9 Evaluation Results	10
2.10 Comments/Recommendations	10
<b>3 Security Target</b>	<b>11</b>
<b>4 Definitions</b>	<b>11</b>
<b>5 Bibliography</b>	<b>13</b>

## Foreword

The Netherlands Scheme for Certification in the Area of IT Security (NSCIB) provides a third-party evaluation and certification service for determining the trustworthiness of Information Technology (IT) security products. Under this NSCIB, TrustCB B.V. has the task of issuing certificates for IT security products, as well as for protection profiles and sites.

Part of the procedure is the technical examination (evaluation) of the product, protection profile or site according to the Common Criteria assessment guidelines published by the NSCIB. Evaluations are performed by an IT Security Evaluation Facility (ITSEF) under the oversight of the NSCIB Certification Body, which is operated by TrustCB B.V. in cooperation with the Ministry of the Interior and Kingdom Relations.

An ITSEF in the Netherlands is a commercial facility that has been licensed by TrustCB B.V. to perform Common Criteria evaluations; a significant requirement for such a licence is accreditation to the requirements of ISO Standard 17025 “General requirements for the accreditation of calibration and testing laboratories”.

By awarding a Common Criteria certificate, TrustCB B.V. asserts that the product or site complies with the security requirements specified in the associated (site) security target, or that the protection profile (PP) complies with the requirements for PP evaluation specified in the Common Criteria for Information Security Evaluation. A (site) security target is a requirements specification document that defines the scope of the evaluation activities.

The consumer should review the (site) security target or protection profile, in addition to this certification report, to gain an understanding of any assumptions made during the evaluation, the IT product's intended environment, its security requirements, and the level of confidence (i.e., the evaluation assurance level) that the product or site satisfies the security requirements stated in the (site) security target.

Reproduction of this report is authorised only if the report is reproduced in its entirety.

## Recognition of the Certificate

Presence of the Common Criteria Recognition Arrangement (CCRA) and the SOG-IS logos on the certificate indicates that this certificate is issued in accordance with the provisions of the CCRA and the SOG-IS Mutual Recognition Agreement (SOG-IS MRA) and will be recognised by the participating nations.

## International recognition

The CCRA was signed by the Netherlands in May 2000 and provides mutual recognition of certificates based on the Common Criteria (CC). Since September 2014 the CCRA has been updated to provide mutual recognition of certificates based on cPPs (exact use) or STs with evaluation assurance components up to and including EAL2+ALC\_FLR.

For details of the current list of signatory nations and approved certification schemes, see <http://www.commoncriteriaportal.org>.

## European recognition

The SOG-IS MRA Version 3, effective since April 2010, provides mutual recognition in Europe of Common Criteria and ITSEC certificates at a basic evaluation level for all products. A higher recognition level for evaluation levels beyond EAL4 (respectively E3-basic) is provided for products related to specific technical domains. This agreement was signed initially by Finland, France, Germany, The Netherlands, Norway, Spain, Sweden and the United Kingdom. Italy joined the SOG-IS MRA in December 2010.

For details of the current list of signatory nations, approved certification schemes and the list of technical domains for which the higher recognition applies, see <https://www.sogis.eu>.

## 1 Executive Summary

This Certification Report states the outcome of the Common Criteria security evaluation of the Security Chip MH1701 with IC Dedicated Software, V05. The developer of the Security Chip MH1701 with IC Dedicated Software, V05 is Beijing Megahunt Technologies Inc. located in Beijing, China and they also act as the sponsor of the evaluation and certification. A Certification Report is intended to assist prospective consumers when judging the suitability of the IT security properties of the product for their particular requirements.

The TOE implements a dedicated security 32-bit RISC CPU designed on the basis of the ARMv6\_Marchitecture designed in 40 nm technology. The TOE offer a wide range of peripherals, including ISO interface, two timers, one watchdog, a CRC module, a true random number generator (TRNG) and a deterministic random number generator (DRNG), coprocessors for symmetric and asymmetric cryptographic algorithms. Additionally, a range of communication interfaces, such as GPIO, NFC.

The TOE comprises the MEGAHUNT security chip MH1701 and IC dedicated software which includes the firmware SBL stored in ROM and software such as Cryptographic libraries (CL). The TOE can be configured as either permanently disabled for the downloader or enabled for the downloader.

The TOE offer all functions that are both required and useful in security systems, and integrated peripherals that are typically needed in chip card applications, such as information security, identification, access control, electronic banking, digital signature and multi-application cards, ID cards, transportation and e-purse applications.

This TOE is critically dependent on the operational environment to provide countermeasures against specific attacks as described in [AGD\_OPE] chapter 3.3, 3.6, and 4, and [AGD\_CL] chapter 3.9 and 4.4. As such it is vital that meticulous adherence to the user guidance of both the software and the hardware part of the TOE is maintained.

The TOE has been evaluated by SGS Brightsight B.V. located in Delft, The Netherlands. The evaluation was completed on 21-11-2025 with the approval of the ETR. The certification procedure has been conducted in accordance with the provisions of the Netherlands Scheme for Certification in the Area of IT Security [NSCIB].

The scope of the evaluation is defined by the security target [ST], which identifies assumptions made during the evaluation, the intended environment for the Security Chip MH1701 with IC Dedicated Software, V05, the security requirements, and the level of confidence (evaluation assurance level) at which the product is intended to satisfy the security requirements. Consumers of the Security Chip MH1701 with IC Dedicated Software, V05 are advised to verify that their own environment is consistent with the security target, and to give due consideration to the comments, observations and recommendations in this certification report.

The results documented in the evaluation technical report [ETR]<sup>1</sup> for this product provide sufficient evidence that the TOE meets the EAL6 augmented (EAL6+) assurance requirements for the evaluated security functionality. This assurance level is augmented with ALC\_FLR.1 (Basic flaw remediation).

The evaluation was conducted using the Common Methodology for Information Technology Security Evaluation, Version 3.1 Revision 5 [CEM] for conformance to the Common Criteria for Information Technology Security Evaluation, Version 3.1 Revision 5 [CC] (Parts I, II and III).

TrustCB B.V., as the NSCIB Certification Body, declares that the evaluation meets all the conditions for international recognition of Common Criteria Certificates and that the product will be listed on the NSCIB Certified Products list. Note that the certification results apply only to the specific version of the product as evaluated.

---

<sup>1</sup> The Evaluation Technical Report contains information proprietary to the developer and/or the evaluator, and is not available for public review.

## 2 Certification Results

### 2.1 Identification of Target of Evaluation

The Target of Evaluation (TOE) for this evaluation is the Security Chip MH1701 with IC Dedicated Software, V05 from Beijing Megahunt Technologies Inc. located in Beijing, China.

The TOE is comprised of the following main components:

Delivery item type	Identifier	Version	
Hardware	Security chip MH1701	V05	
Software	Security IC Dedicated Software	03	
	Security IC Dedicated Software consisting of	Security Boot Loader	V0.7
		Cryptographic library and header files	V3.0
	Security API library and header files	V3.0	

To ensure secure usage a set of guidance documents is provided, together with the Security Chip MH1701 with IC Dedicated Software, V05. For details, see section 2.5, Documentation.

### 2.2 Security Policy

The TOE is a single chip microcontroller with IC Dedicated Software with large amount of memory and special peripheral devices with improved performance, optimized power consumption, at minimal chip size. The TOE with its integrated security features meets the security requirements of a variety of applications (see chapter1). The security functionality is described as follows: The TOE maintains:

- The integrity and confidentiality of code and data stored in its memories
- The different CPU modes with the related capabilities for configuration and memory access
- The integrity, the correct operation and the confidentiality of security functionality provided by the TOE This is ensured by the construction of the TOE and its security functionality.

The TOE provides crypto functionality like

- TDES, AES, RSA, Elliptic Curve (EC) cryptography
- A True Random Number Generator

In addition, several security mechanisms are implemented to ensure proper operation as well as integrity and confidentiality of stored data.

The user of the TOE is the developer of the Embedded Software.

### 2.3 Assumptions and Clarification of Scope

#### 2.3.1 Assumptions

The assumptions defined in the Security Target are not covered by the TOE itself. These aspects lead to specific Security Objectives to be fulfilled by the TOE-Environment. For detailed information on the security objectives that must be fulfilled by the TOE environment, see section 5.3 of the [ST].

#### 2.3.2 Clarification of scope

The evaluation did not reveal any threats to the TOE that are not countered by the evaluated security functions of the product.

## 2.4 Architectural Information

The TOE is a smart card IC with memory and peripheral devices, optimized power consumption, at minimal chip size while implementing high security. The TOE with its integrated security features meets the security requirements of all smart card applications such as information integrity protection, access control, (U)SIM of the mobile telephone and identification card, as well as electronic funds transfer and healthcare systems. The security functionality is described as follows:

- The major components of the core system are the 32-bit CPU as a variant of the ARM Secure Core with security mechanisms supporting two modes: unprivileged and privilege
- Bus polarity switching
- The TOE provides a robust set of sensors for the purpose of monitoring proper chip operating conditions and detecting fault attacks including temperature sensor, internal frequency sensor, voltage sensor, glitch sensor and light sensor
- AES with countermeasures against SPA, DPA, EMA, DEMA and DFA attacks
- Triple-DES with countermeasures against SPA, DPA, EMA, DEMA and DFA attacks
- RSA cryptography with countermeasures against SPA, DPA, EMA, DEMA and DFA attacks
- Elliptic Curve (EC) cryptography with countermeasures against SPA, DPA, EMA, DEMA and DFA attacks
- The TOE provides True Random Number Generator (TRNG) specially designed for smart card applications are implemented. The TRNG fulfills the requirements from the functionality class PTG.2 of AIS31
- The TOE provides Deterministic Random Number Generator (DRNG), which compliant with DRG.3 class of AIS31
- Memory access control and the enhanced Memory Protection Unit (eMPU)
- Specific active shielding that against probing and physical manipulation attacks
- Memory Encryption/Decryption Unit provides encryption of all memories inside the chip (RAM, CRAM, NVM and OTP)
- Parity check for RAM, CRAM, NVM/OTP and some critical registers
- Test mode and downloader blocking protection
- Downloader disabling and protection (only for downloader is valid)

The TOE contains the following functions, but these security functions are not claimed:

- Chinese domestic cryptographic function
- Single DES cryptographic function
- Hash functions for the SHA-1 and SHA-2 family
- Checksum module (CRC)

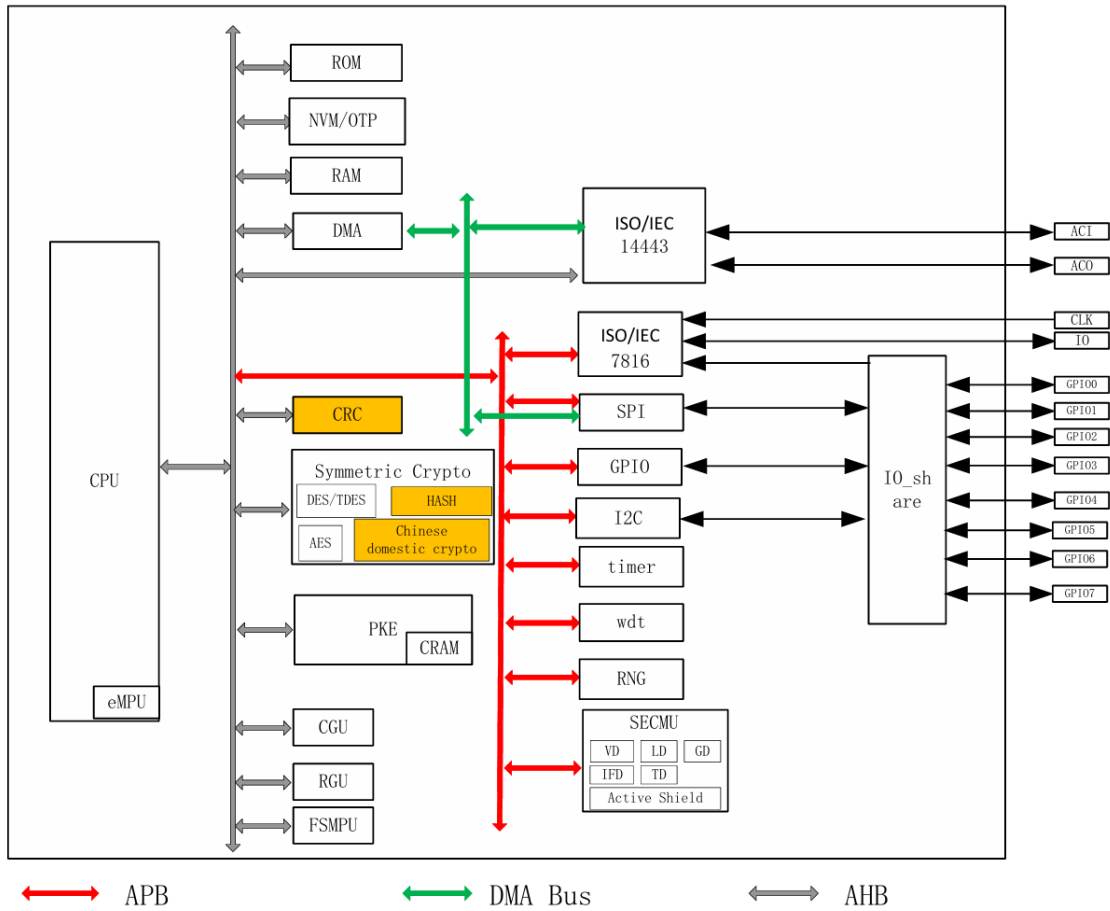

Figure 1 Logical architecture of the TOE

## 2.5 Documentation

The following documentation is provided with the product by the developer to the customer:

Identifier	Version
MH1701 Security Chip V05 Cryptographic Library Interface Manual	V1.0
MH1701 Security Chip V05 Security API Library Interface Manual	V1.0
MH1701 Security Chip V05 Bootloader User Guidance specification	V1.0
The datasheet of MH1701 Security Chip V05	V1.0
MH1701 Security Chip V05 User Operational Guidance	V1.0
MH1701 Security Chip V05 Preparative Procedures	V1.0

## 2.6 IT Product Testing

Testing (depth, coverage, functional tests, independent testing): The evaluators examined the developer’s testing activities documentation and verified that the developer has met their testing responsibilities.

### 2.6.1 Testing approach and depth

The developer has performed extensive testing on functional specification, subsystem and module level. The testing has been performed in four categories:

- Hardware: simulation tests, sample tests, wafer tests, qualification and characterization tests.

- Secure Boot Loader: simulation tests, sample tests, wafer tests.
- Cryptographic library: simulation tests, sample tests, wafer tests.
- Security API library: simulation tests, sample tests, wafer tests.

All TSFIs, subsystems and modules are tested.

The underlying hardware and crypto-library test results are extendable to composite evaluations, as the underlying platform is operated according to its guidance and the composite evaluation requirements are met.

For the testing performed by the evaluators, the developer provided samples which are identical with the TOE. The evaluators reproduced a selection of the developer tests, as well as a number of test cases designed by the evaluator.

### 2.6.2 Independent penetration testing

The total test effort expended was 50 man weeks in total for testing and reporting. During that test campaign, 5% of the total time was spent on the physical attack, 25% of the total time was spent on perturbation attacks, 15% on retrieving keys with FA, 45% on side-channel attacks, 10% on attacks on RNG, 0% on exploitation of test features and 0% on software attack.

### 2.6.3 Test configuration

The configuration of the sample used for independent evaluator testing and penetration testing was the same as described in the [ST]. Several versions of Test OS were developed by the developer according to the evaluators test requirements and update requests.

### 2.6.4 Test results

The testing activities, including configurations, procedures, test cases, expected results and observed results are summarised in the [ETR], with references to the documents containing the full details.

The developer's tests and the independent functional tests produced the expected results, giving assurance that the TOE behaves as specified in its [ST] and functional specification.

No exploitable vulnerabilities were found with the independent penetration tests.

The algorithmic security level of cryptographic functionality has not been rated in this certification process, but the current consensus on the algorithmic security level in the open domain, i.e., from the current best cryptanalytic attacks published, has been taken into account.

Not all key sizes specified in the [ST] have sufficient cryptographic strength for satisfying the AVA\_VAN.5 "high attack potential". The TOE supports a wider range of key sizes (see [ST]), including those with sufficient algorithmic security level to exceed 100 bits as required for high attack potential (AVA\_VAN.5).

The strength of the implementation of the cryptographic functionality has been assessed in the evaluation, as part of the AVA\_VAN activities.

For composite evaluations, please consult the [ETRFc] for details.

## 2.7 Reused Evaluation Results

There has been extensive reuse of the ALC aspects for the sites involved in the development and production of the TOE, by use of three site certificates and one Site Technical Audit Report.

One site has been visited as part of this evaluation.

## 2.8 Evaluated Configuration

The TOE is defined uniquely by its name and version number Security Chip MH1701 with IC Dedicated Software, V05. In [AGD\_OPE] section 2 the method of TOE identification is described.

## 2.9 Evaluation Results

The evaluation lab documented their evaluation results in the [ETR], which references an ASE Intermediate Report and other evaluator documents, and Site Technical Audit Report for the site [STAR]<sup>2</sup>. To support composite evaluations according to [COMP] a derived document [ETRFc] was provided and approved. This document provides details of the TOE evaluation that must be considered when this TOE is used as platform in a composite evaluation.

The verdict of each claimed assurance requirement is “Pass”.

Based on the above evaluation results the evaluation lab concluded the Security Chip MH1701 with IC Dedicated Software, V05, to be **CC Part 2 extended, CC Part 3 conformant**, and to meet the requirements of **EAL 6 augmented with ALC\_FLR.1**. This implies that the product satisfies the security requirements specified in Security Target [ST].

The Security Target claims 'strict' conformance to the Protection Profile [PP].

## 2.10 Comments/Recommendations

” contains necessary information about the usage of the TOE. Certain aspects of the TOE’s security functionality, in particular the countermeasures against attacks, depend on accurate conformance to the user guidance of both the software and the hardware part of the TOE. There are no particular obligations or recommendations for the user apart from following the user guidance. Please note that the documents contain relevant details concerning the resistance against certain attacks.

This TOE is critically dependent on the operational environment to provide countermeasures against specific attacks as described in [AGD\_OPE] chapter 3.3, 3.6, and 4, and [AGD\_CL] chapter 3.9 and 4.4.. As such it is vital that meticulous adherence to the user guidance of both the software and the hardware part of the TOE is maintained.

In addition, all aspects of assumptions, threats and policies as outlined in the Security Target not covered by the TOE itself must be fulfilled by the operational environment of the TOE.

The customer or user of the product shall consider the results of the certification within his system risk management process. For the evolution of attack methods and techniques to be covered, the customer should define the period of time until a re-assessment for the TOE is required and thus requested from the sponsor of the certificate.

The strength of the cryptographic algorithms and protocols was not rated in the course of this evaluation. This specifically applies to the following proprietary or non-standard algorithms, protocols and implementations: none

Not all key sizes specified in the [ST] have sufficient cryptographic strength to satisfy the AVA\_VAN.5 “high attack potential”. To be protected against attackers with a “high attack potential”, appropriate cryptographic algorithms with sufficiently large cryptographic key sizes shall be used (references can be found in national and international documents and standards).

---

<sup>2</sup> The Site Technical Audit Report contains information necessary to an evaluation lab and certification body for the reuse of the site audit report in a TOE evaluation.

### 3 Security Target

The Security Target of Security Chip MH1701 V05 with IC Dedicated Software, Version 1.7, August 7, 2025 [ST] is included here by reference.

Please note that, to satisfy the need for publication, a public version [ST-lite] has been created and verified according to [ST-SAN].

### 4 Definitions

This list of acronyms and definitions contains elements that are not already defined by the CC or CEM:

AES	Advanced Encryption Standard
CBC	Cipher Block Chaining (a block cipher mode of operation)
CRAM	Compressed Random Access Memory
DEMA	Differential Electromagnetic Analysis
DES	Data Encryption Standard
DFA	Differential Fault Analysis
EC	Elliptic Curve
ECB	Electronic Code Book (a block-cipher mode of operation)
ECC	Elliptic Curve Cryptography
ECDH	Elliptic Curve Diffie-Hellman algorithm
ECDSA	Elliptic Curve Digital Signature Algorithm
ECIES	Elliptic Curve Integrated Encryption Scheme
EMA	Electromagnetic Analysis
eMPU	enhanced Memory Protection Unit
IC	Integrated Circuit
IT	Information Technology
ITSEF	IT Security Evaluation Facility
JIL	Joint Interpretation Library
JIL	Joint Interpretation Library
NSCIB	Netherlands Scheme for Certification in the area of IT Security
NVM	Non-Volatile Memory
OPT	One-Time Programmable
PKI	Public Key Infrastructure
PP	Protection Profile
RAM	Random Access Memory
RNG	Random Number Generator
RSA	Rivest-Shamir-Adleman Algorithm
SHA	Secure Hash Algorithm
SPA/DPA	Simple/Differential Power Analysis
TDES	Triple DES



TOE                      Target of Evaluation  
TRNG                    True Random Number Generator

## 5 Bibliography

This section lists all referenced documentation used as source material in the compilation of this report.

- [CC] Common Criteria for Information Technology Security Evaluation, Parts I, II and III, Version 3.1 Revision 5, April 2017
- [CEM] Common Methodology for Information Technology Security Evaluation, Version 3.1 Revision 5, April 2017
- [COMP] Joint Interpretation Library, Composite product evaluation for Smart Cards and similar devices, Version 1.5.1, May 2018
- [ETR] Evaluation Technical Report “Security Chip MH1701 with IC Dedicated Software, V05” – EAL6+, 25-RPT-1000, Version 5.0, 31 October 2025
- [ETRFc] Evaluation Technical Report for Composition “Security Chip MH1701 with IC Dedicated Software, V05” – EAL6+, 25-RPT-018, Version 3.0, 31 October 2025
- [JIL-AAPS] JIL Application of Attack Potential to Smartcards, Version 3.2.1, February 2024
- [JIL-AMS] Attack Methods for Smartcards and Similar Devices, Version 2.5, May 2022 (sensitive with controlled distribution)
- [NSCIB] Netherlands Scheme for Certification in the Area of IT Security, Version 2.6, 02 August 2022
- [PP\_0084] Security IC Platform Protection Profile with Augmentation Packages, registered under the reference BSI-CC-PP-0084-2014, Version 1.0, 13 January 2014
- [ST] Security Target of Security Chip MH1701 V05 with IC Dedicated Software, Version 1.7, August 7, 2025
- [STlite] Security Target Lite of Security Chip MH1701 V05 with IC Dedicated Software, Version V1.1, August 7, 2025
- [ST-SAN] ST sanitising for publication, CC Supporting Document CCDB-2006-04-004, April 2006
- [STAR] Site Technical Audit Report Megahunt Beijing Site, 25-RPT-960, Version V1.0, 31 July 2025

(This is the end of this report.)